

L(Transvector)	T	B	B1	Q	A
3"	76, 2mm	120, 1	38, 1	41	1 (centre)
6"	152, 4mm	196, 2	76, 2	60	1 (centre)
12"	304, 8mm	348, 6	228, 6	60	1 (centre)
18"	457, 2mm	501, 0	381, 0	60	2 228, 6
24"	609, 6mm	653, 4	533, 4	60	2 304, 8
(30")	771, 0mm	814, 6	694, 6	60	3 257, 0
(36")	923, 4mm	967, 0	847, 0	60	3 307, 8
(42")	1075, 8mm	1119, 4	999, 4	60	4 269, 0
(48")	1228, 2mm	1271, 8	1151, 8	60	4 307, 1
(54")	1389, 6mm	1433, 0	1313, 0	60	5 277, 9
(60")	1542, 0mm	1585, 4	1465, 4	60	5 308, 4
(66")	1694, 4mm	1737, 8	1617, 8	60	6 282, 4
(72")	1846, 8mm	1890, 2	1770, 2	60	6 307, 8

NOTE:

Q = Quantity of Air connections G 1/4"

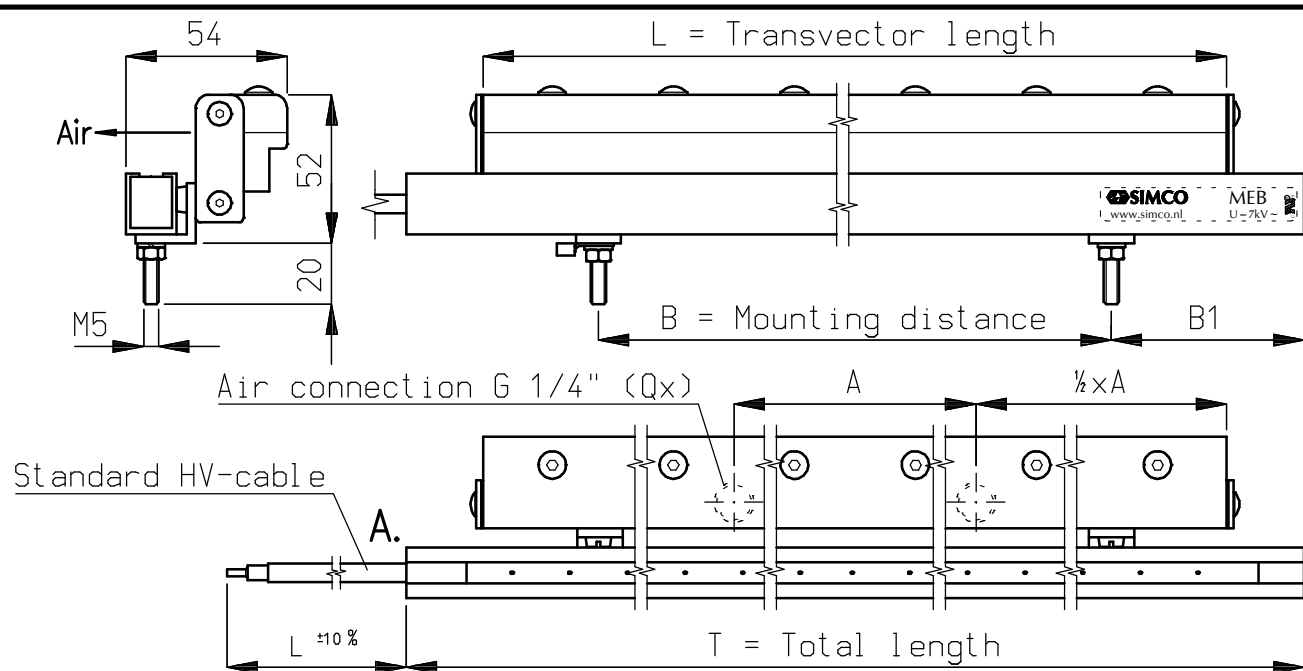

Standard mounting brackets/ cable clamps

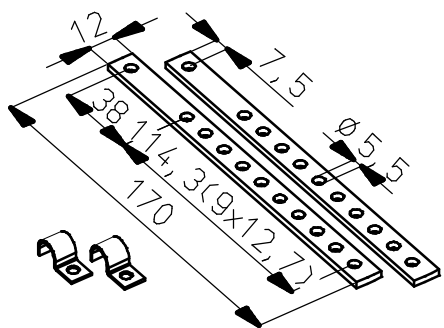

Amount of cable clamps=
(cable length(m)x4)-1

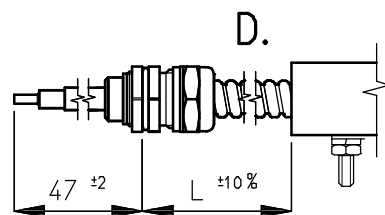

Cable exit options: with shielded HV-cable

